

HIT photovoltaic module

HIP-195BKB1 HIP-190BKB1

The SANYO HIT (Heterojunction with Intrinsic Thin layer) solar cell is made of a thin mono crystalline silicon wafer surrounded by ultra-thin amorphous silicon layers. This product provides the industry's leading performance and value using state-of-the-art manufacturing techniques.



Benefit in Terms of Performance

The HIT cell and module have very high conversion efficiency in mass production.

Model	Cell Efficiency	Module Efficiency
HIP-195BKB1	19.3%	16.5%
HIP-190BKB1	18.8%	16.1%

High performance at high temperatures

Even at high temperatures, the HIT solar cell can maintain higher efficiency than a conventional crystalline silicon solar cell.

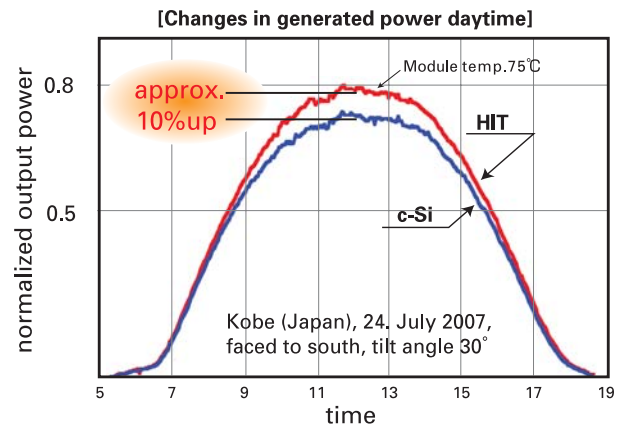

HIT Solar Cell Structure

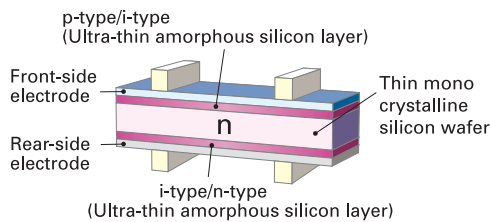

Development of HIT solar cell was supported in part by the New Energy and Industrial Technology Development Organization (NEDO).

Environmentally-Friendly Solar Cell More Clean Energy

HIT can generate more clean Energy than other conventional crystalline solar cells.

Special Features

SANYO HIT solar modules are 100% emission free, have no moving parts and produce no noise. The dimensions of the HIT modules allow space-saving installation and achievement of maximum output power possible on given roof area.

Models HIP-xxxBKB1			
Electrical data		195	190
Maximum power (Pmax)	[W]	195	190
Max. power voltage (Vmp)	[V]	55.3	54.8
Max. power current (Imp)	[A]	3.53	3.47
Open circuit voltage (Voc)	[V]	68.1	67.5
Short circuit current (Isc)	[A]	3.79	3.75
Warranted minimum power (Pmin)	[W]	185.25	180.5
Maximum over current rating	[A]	15	
Output power tolerance	[%]	+10/-5	
Maximum system voltage	[Vdc]	1000	
Temperature coefficient of Pmax	[%/°C]	-0.30	-0.30
	Voc [V/°C]	-0.170	-0.169
	Isc [mA/°C]	0.87	0.86

Note 1: Standard Test Conditions: Air mass 1.5, Irradiance = 1000W/m², Cell temperature = 25°C
 Note 2: The values in the above table are nominal

Reference data for model HIP-195BKB1

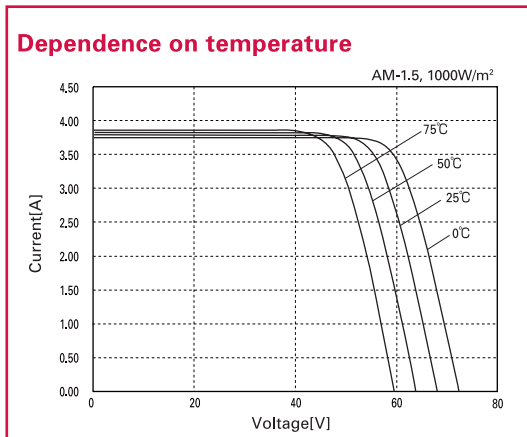
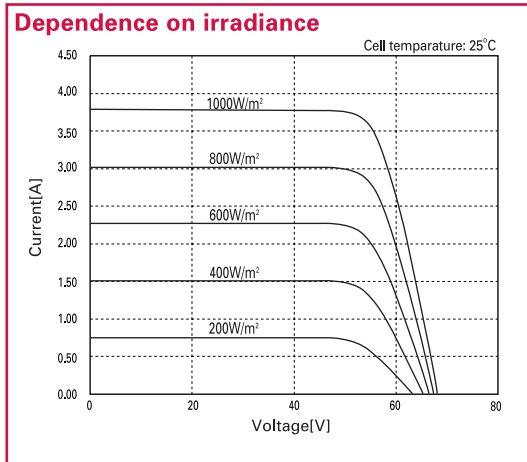

Certificates

Please consult your local dealer for more information.

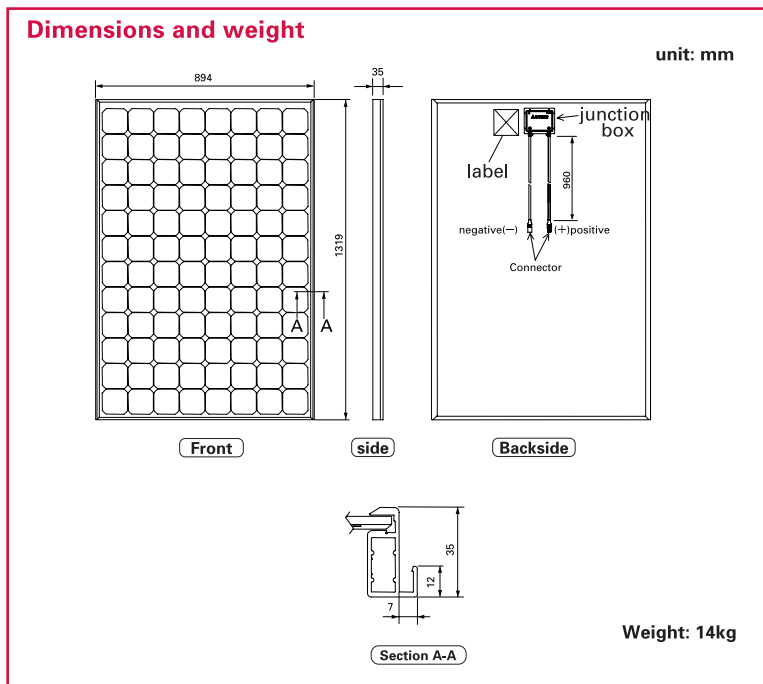

Warranty

Power output: 20 years (80% of minimum output power)
 Product workmanship: 2 years
 (Based on contract terms)

Certificate Number: PV05-53203-1003

An above number is a certification number by JET.
 JET: Japan Electrical Safety & Environment Technology Laboratories

CAUTION! Please read the operating instructions carefully before using the products.

Due to our policy of continual improvement the products covered by this brochure may be changed without notice.

[ASIA & Oceania]

SANYO Electric Co.,Ltd.
 Overseas Sales & Marketing Headquarters
 Tel.81-6-6994-7359 Fax.81-6-6994-3183

[Africa]

SANYO South Africa (Pty) Ltd.
 Tel.27-11-448-2929 Fax.27-11-448-2860

[Middle East]

SANYO Gulf FZE
 Tel.971-4-887-3939 Fax.971-4-887-3969



SANYO Electric Co.,Ltd
Clean Energy Company

http://www.sanyo.co.jp/clean/solar/hit_e/index_e.html
 email: homepage_solar@sanyo.com